

**FloTech  
FT208  
CheckMate  
Programmable  
Retain / Overflow  
Onboard Monitor**

**Dixon Bayco  
FloTech Division  
Cincinnati, Ohio**

# FloTech Programmable CheckMate Retain / Overfill Monitor

**Table of Contents**

Introduction..... 4

Monitor Features..... 4

Monitor Indicators ..... 5

Monitor Connections ..... 5

Mounting Instructions..... 6

    Monitor Housing..... 6

Cable Installation Instructions ..... 7

    Monitor Housing..... 7

Wiring Instructions ..... 8

    Proper Wire Connections..... 8

    Monitor Wiring Connections ..... 9

        TB1 POWER Connections ..... 10

        TB2 TOP and BOTTOM SENSOR Connections..... 10

        TB4 AUX PERMIT Connections ..... 11

        TB5 PROGRAM Connections..... 14

        FLOAT, THERMISTOR and OPTIC Rack Connections..... 11

Programming..... 15

    Overview..... 15

    Procedure ..... 15

Operation..... 17

    Normal Operation ..... 17

Troubleshooting ..... 18

Technical Support Hotline ..... 23

## Introduction

This Manual describes the features, installation, programming, operation, and troubleshooting techniques for the FloTech FT208 CheckMate Programmable Retain / Overfill Onboard Monitor.

## Monitor Features

The FloTech FT208 CheckMate Retain / Overfill Monitor has the following features:

- Operates on 12 VDC or 24 VDC systems.
- Monitors up to eight overfill sensors.
- Monitors up to eight retain sensors.
- Top Only or Top and Bottom configuration.
- Connects to Float, Thermistor or Optic style rack.
- Non I.S. Relay Output
  1. 12 VDC, 1 AMP. MAX.
  2. Permissive: Closed
  3. Non-Permissive: Open
- The monitor is field programmable.
- Simple Wiring – no jumpers, terminators, or dummies.
- Compatible with Two Wire or Five Wire type sensors.

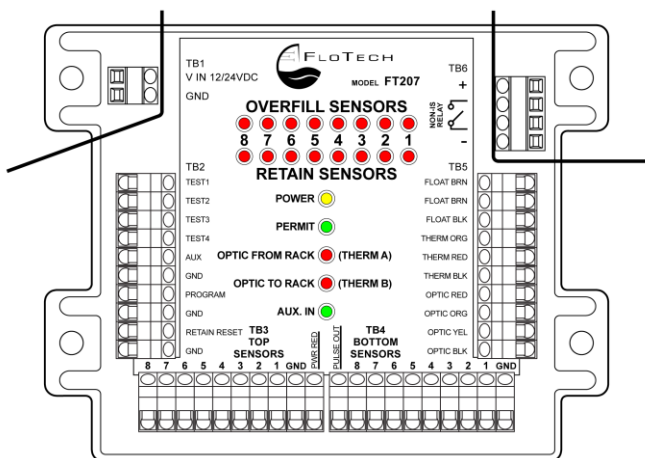


Fig. 1 FT208 Monitor

## Monitor Indicators

Refer to Fig. 1.

### **PWR LED**

Yellow LED that indicates power is connected to the monitor.

### **PERMIT LED**

Green LED indicates to the rack the sensors are permissive.

### **TOP LEDs**

Overfill Sensor Indicators, ON indicates a wet sensor.

### **BOTTOM LEDs**

Retain Sensor Indicators, ON indicates a wet sensor.

### **OPTIC FROM RACK (THERM A) LED**

Red LED indicates no pulse from Optic Rack Monitor (YEL) or no signal to Thermistor Rack Monitor (RED) A channel.

### **OPTIC TO RACK (THERM B) LED**

Red indicates no signal to Optic Rack Monitor (ORG) or no signal to Thermistor Rack Monitor (ORG) B channel.

### **AUX LED**

Green LED indicates the Auxiliary input is permissive.

## Monitor Connections

**TB1** – 12/24 VDC Power Connections

**TB2** – Aux Input and Retain Reset. Program Key Input.

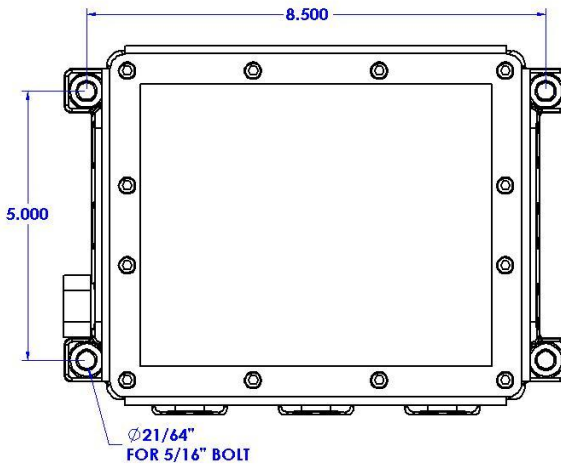
**TB3** – Overfill Sensor Inputs

**TB4** – Retain Sensor Inputs

**TB5** – Optic and Thermistor Socket Connections

**TB6** – Non I.S. Output Relay

## Mounting Instructions



**Fig. 2**  
**Mounting Hole Detail**

### ***Monitor Housing***

The FloTech model FT208 CheckMate Retain / Overfill Monitor Housing is typically mounted in the trailer fitting storage box or any flat surface within easy view of the bottom loading connections. Leave the top cover on the monitor housing and hold it in the position you wish to mount it. Using a black marker, transfer the pattern of the four mounting holes to the mounting surface. BEFORE drilling, check to make sure you will not drill through or damage any existing trailer wiring or piping. Drill the holes through and mount the monitor using four 5/16 inch nuts and bolts.

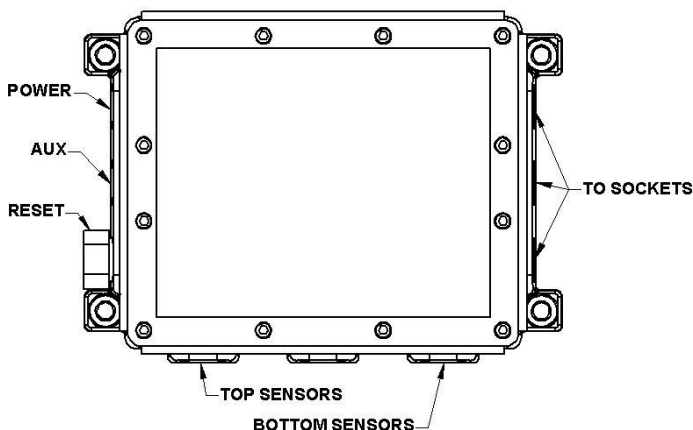
## ***Cable Installation Instructions***

FloTech recommends you use FT404 jacketed 11-conductor cable for up to eight compartment systems. This cable is specially designed to be oil, UV, and abrasion resistant. It incorporates a noble tin-plated stranded copper wire which resists corrosion. When installed properly, this cable will provide years of reliable service. See the Proper Wire Connections section for more detailed directions about stripping and terminating the cables.

## ***Monitor Housing***

After the monitor housing is mounted, install FloTech FT402 cable glands in the openings where needed. These are, as illustrated in Fig.3: Power, Top Sensors, Bottom Sensors, (if equipped) and Socket. Route the lengths of FloTech FT404 cable through the conduit openings. Cut the cables to length leaving approximately 8 inches of extra length inside the monitor housing.

Unused conduit openings in the sensor housings must have a ½ inch NPT pipe plug installed. Note that when using the FloTech FT390 Dual Socket Assembly, you only need to install one cable gland for the socket wiring.



**Fig. 3**  
**Monitor Housing Cable Routing Diagram**

## Wiring Instructions

### ***Proper Wire Connections***

Please read this section of the manual before attempting to wire the FloTech FT208 Monitor. This section recommends some ‘guidelines’ for installing the system wiring that, when done properly, will insure a long, trouble free service life for your equipment.

### **CABLE STRIPPING**

FloTech recommends using FT404 eleven conductor cable to wire the Onboard Monitor System for up to eight compartment systems. When stripping the rubber jacket from the cable, FloTech recommends using the FT9023 or equivalent Cable Stripper. This stripper has an adjustable cutting blade depth setting. The depth should be set to only cut through one-half to two-thirds of the outer jacket thickness. This will insure that the insulation on the inner conductors is not nicked. Any nicks or cuts in the wire insulation can, over time, degrade the quality of the wire and lead to intermittent or total failure.

**CAUTION: Razor Knives Will Cut The Inside Wire Insulation**

### **SPLICE END CONNECTIONS**

FloTech recommends using the FT9024 or equivalent Crimp Tool for securing the splice end connections. Follow this process to secure each connection:

1. Follow the Cable Stripping instructions in the previous paragraph to expose the individual conductors of the wire.
2. Strip the insulation back on each conductor approximately 1/2 inch. Take care not to cut off any strands of wire. If too many strands were accidentally cut off, cut the wires flush with the insulation and strip again.
3. Hold the two wires to be connected together by the insulation. Tightly twist the bare wires together. This insures a good electrical connection.
4. Fill a FloTech 10112 splice end with Silicone RTV compound. Insert the twisted wires into the filled splice.

## FloTech Programmable CheckMate Retain / Overfill Monitor

Check to see that the bare wires are fully inserted into the splice and RTV. Make certain that NO bare wire is protruding from the splice.

5. Securely crimp the wires into the splice end.
6. Give the splice and the wires a ‘tug’ to make sure you have a good mechanical connection.

### TERMINAL BLOCK CONNECTIONS

Follow this process to secure each connection:

1. Strip approximately 3/8 inch of insulation back from the end of the wires.
2. Tightly twist the strands of wire together.
3. Rotate the terminal block screws counterclockwise a few turns to relieve pressure on the wire retainer.
4. Insert the bare wire end into the terminal block.
5. While holding the wire in place, rotate the terminal screw clockwise to tighten the wire retainer.
6. Once fully tightened, give the wire a slight ‘tug’ to insure that a proper connection has been made.

### *Monitor Wiring Connections*

Before attaching wires to the FT208 CheckMate Monitor, please read the following:

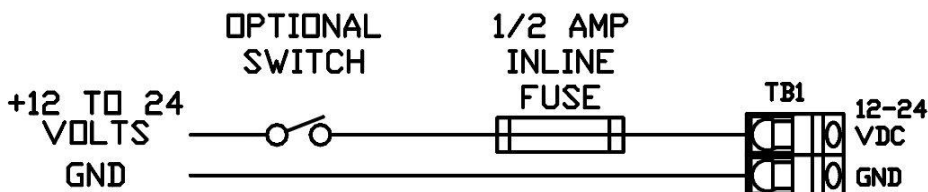
**CAUTION:** Turn off or disconnect power to the trailer before wiring the monitor.

**CAUTION:** Only use the conduit opening marked “POWER INPUT” as shown in Fig.3 to wire power to the monitor.

**CAUTION:** The FloTech FT208 CheckMate Monitor will not work on POSITIVE GROUND electrical systems. Any attempt to wire the monitor to a positive ground system will damage the monitor and void the warranty.

## TB1 POWER Connections

Refer to Fig. 4. FloTech recommends routing the trailer power through a weatherproof inline fuse holder (supplied) containing a 1/2 amp fast blow fuse to the monitor. Optionally, a switch can be added in series with the fuse to the TB1 input. Connect the positive power supply wire to the TB1 terminal marked “12/24 VDC”. This is the upper screw on TB1. Be careful that no stray wires are touching the metal barrier or ground terminal. The Ground wire connects to the TB1 terminal marked GND.



**Fig. 4**  
**Monitor Power Connections**

## TB3 & 4 TOP and BOTTOM SENSOR Connections

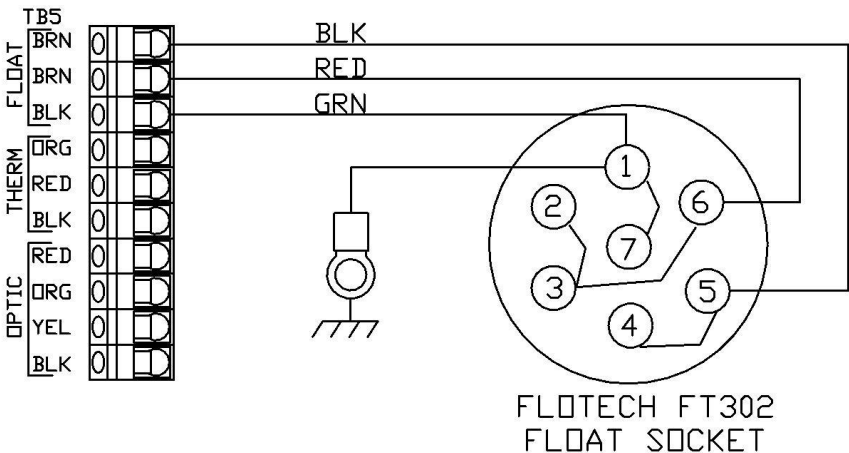
FloTech FT208 can be wired to work with 2 wire FT151 sensors or API 5 wire FT101 sensors. FloTech recommends wiring the sensors to the FT208 Monitor using FT404 11 conductor cable for up to 8 compartment systems. FloTech FT404 cable is color coded to ease installation and troubleshooting. A color coded wiring schematic is provided in the back of this manual.

## TB5 Socket Connections

These connections are wired to the appropriate socket(s) as dictated by the Loading Terminals in your area. At this time, FloTech offers the following sockets:

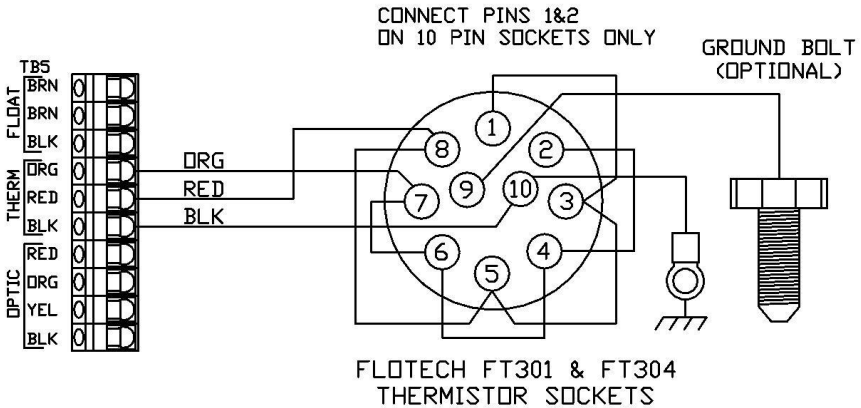
- FT300 Series API Optic Socket
- FT301 Series API Thermistor Socket
- FT302 Series API Float Socket
- FT303 Series Optic Contact Pattern with Thermistor J slot
- FT304 Series Canadian / Euro Thermistor Socket
- FT305 J560 Type Thermistor Socket
- FT306 J560 Type Optic Socket
- FT390 Series API Dual Thermistor and Optic Sockets
- FT391 Series API Dual Optic and Thermistor Sockets
- FT393 API/J560 Triple Socket
- FT394 Series API/J560 Triple Socket
- FT395 Series API/J560 Triple Socket

Refer to Figs. 6 through 9 for socket wiring.

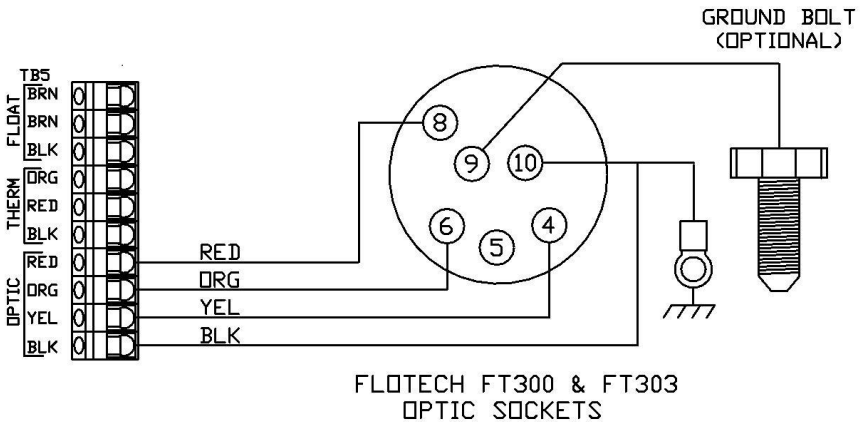


**Fig 6.**  
**Float Socket Connections**

# FloTech Programmable CheckMate Retain / Overfill Monitor



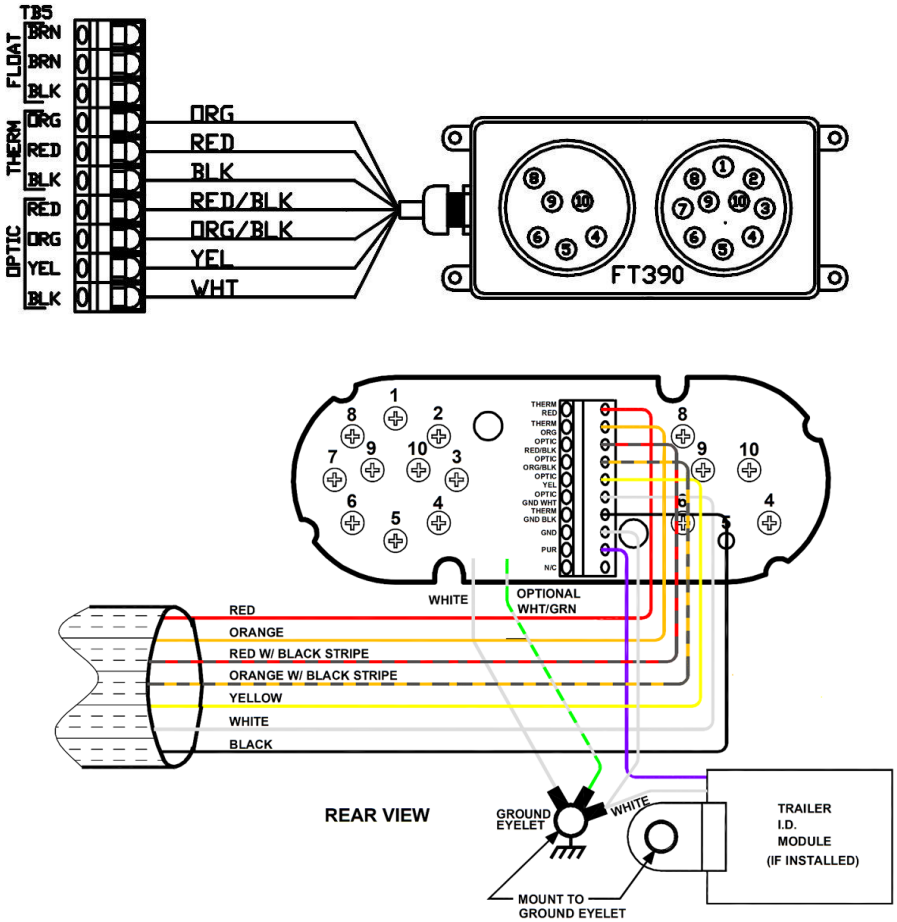
**Fig. 7**  
**Thermistor Socket Connections**



**Fig. 8**  
**Optic Socket Connections**

Another Socket Option is to install the FloTech FT390 Dual Socket Assembly. This unit comes with the sockets pre-wired to a length of FloTech eleven conductor cable. Refer to Fig. 9 for wiring connections.

# FloTech Programmable CheckMate Retain / Overfill Monitor



**Fig. 9**  
**FloTech FT390 and FT208-390 Series Socket Connections**

## TB2 AUX PERMIT Connections

Refer to Fig. 10. In order for the FT208 Monitor to work properly, the AUX terminals must be connected together. This can be done either by placing a shorting jumper across the AUX terminals (factory installed) or by connecting the AUX terminals to a dry relay contact. Examples of this would be a Hobbs switch or a

Vapor Recovery interlock switch. When the AUX connection is made, the FT208 Monitor issues a PERMIT signal.

## TB2 RETAIN RESET Connections

Refer to Fig. 10. The Retain Reset terminals connect to a Normally Open push button switch. The primary function of this switch is to override wet Retain Sensors for ‘Splash Blending’ product. When this button is pressed, the FT208 Monitor will issue a Permit signal to the Rack without regard to the Retain Sensors. The Permit signal will be disabled if any of the Overfill Sensors become wet or there is signal activity on any Retain Sensors that have been programmed as inactive.

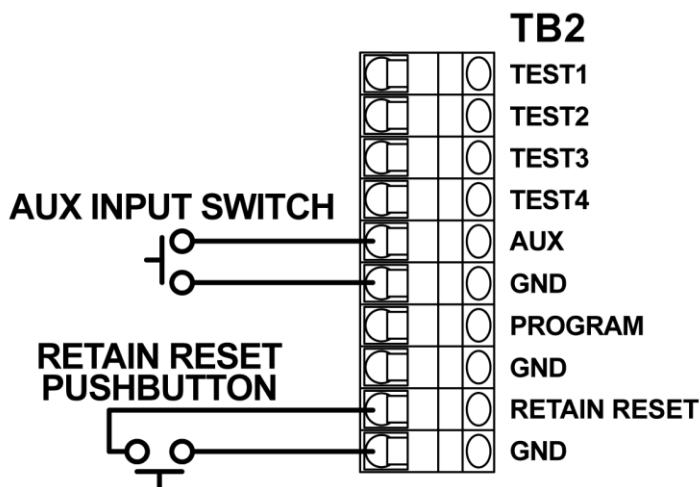


Fig. 10  
Retain Reset and AUX Connections

## TB2 PROGRAM Connections

Refer to Fig. 10. The FT208 Monitor must have a program module installed in the PROGRAM terminals **ONLY** during programming

of the monitor. This connection must be left open for normal operation. See the Programming Section of this manual for detailed instructions about programming this unit.

## **Programming**

### **Overview**

Before the FloTech FT208 Monitor can be put into service, it must be programmed. This procedure informs the monitor which inputs have sensors attached. These inputs are then labeled as ACTIVE sensors. The remaining inputs that do NOT have sensors attached are labeled as INACTIVE inputs. This insures that a PERMIT signal will be issued only if ALL of the following conditions are met:

- All active overfill sensors are dry.
- All inactive overfill sensors are not connected.
- All active retain sensors are dry or the Retain Reset button has been pressed.
- All inactive retain sensors are disconnected.
- The AUX input is jumpered or made through an external contact.

If ANY of the above conditions are not met, the PERMIT signal will not be generated.

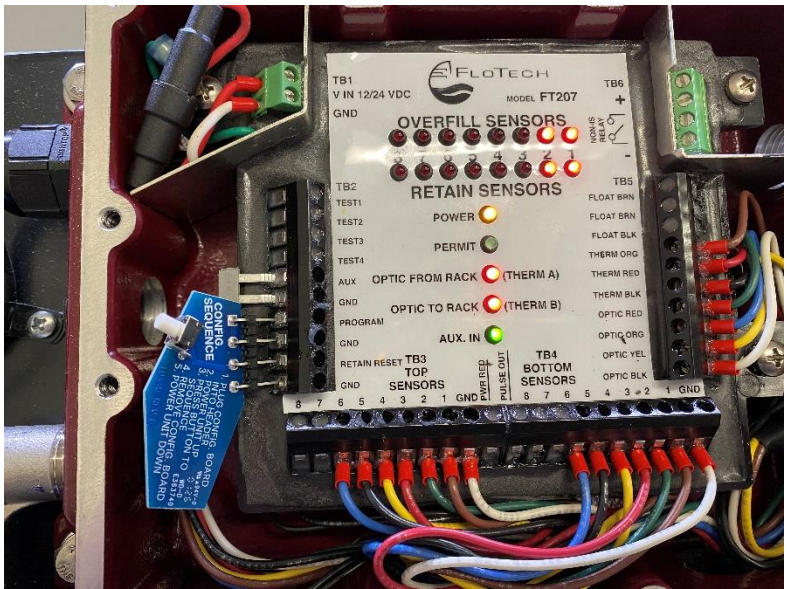
Programming is accomplished in the following manner:

### **Procedure**

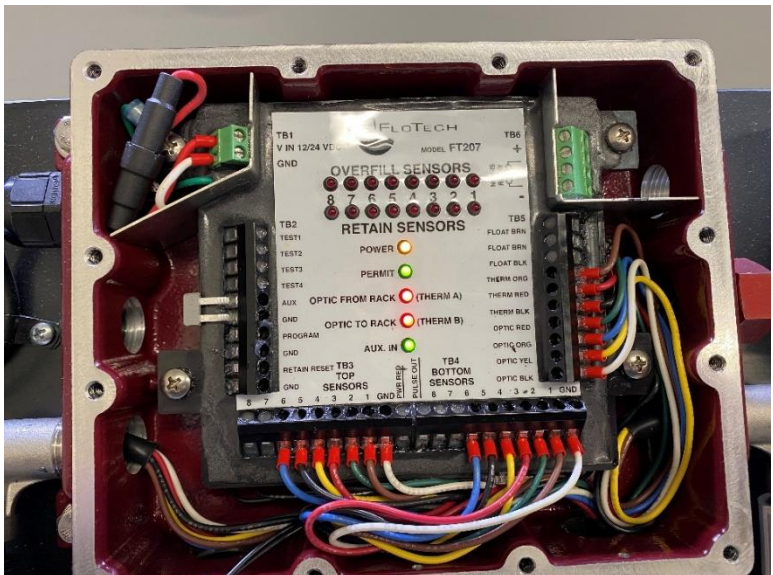
To program the FT208 monitor:

1. With the monitor off, install as shown and then turn power on. Push the button to match the configuration of the trailer. Example: 2 compartment top and bottom.

## FloTech Programmable CheckMate Retain / Overfill Monitor



2. Remove the board with the monitor power on.



3. Replace retain reset wires.

## Operation

### ***Normal Operation***

When power is applied to the FT208 monitor, the unit will sequentially flash the sensor LEDs through the power up test pattern. This sequence is from the TOP #1 LED to the TOP #8 LED then from the BOTT #1 LED to the BOTT #8 LED.

Once this sequence is completed, the unit tests all the sensor inputs.

## FloTech Programmable CheckMate Retain / Overfill Monitor

A PERMIT signal will be issued if:

- All the sensor inputs that have been programmed as active see dry sensor signals.
- Any of the Retain sensors are wet and the Retain Reset pushbutton has been pressed.
- All the sensor inputs that have been programmed as inactive see no signals.
- The AUX input is jumpered or made through an external set of contacts.

A PERMIT signal will NOT be issued if:

- Any of the sensors that have been programmed as active are wet or are not connected.
- Any of the sensors that have been programmed as inactive see a sensor signal.
- The AUX input is not jumpered or made through an external set of contacts.

## Retain Sensor Override

Should a driver wish to load over retained product, such as splash blending, the driver must do the following:

1. Connect the API plug from the rack to the optic or thermistor socket on the trailer. The monitor will be in a non-permissive state (Green Permit led will be off).
2. Press the Retain Reset switch. The monitor is now in a permissive state (Green Permit led will be on) and a permit load signal will be sent to the loading rack.
3. The monitor will remain in a permissive state until the API plug is removed from the trailer socket. Then the monitor will switch to a non-permissive state and prevent future loading until the API plug is again connected to a rack.

## Troubleshooting

Look up symptoms below and follow step by step instructions.

### **The PWR LED is not lit.**

Measure the voltage on TB1. The input voltage must be between 11 and 24 VDC.

If the voltage is zero or low, work your way up the wiring to the trailer nose plug. Check the inline fuse holder for bad connections and for a blown fuse. Check the wiring and trailer nose plug connections. Fuse housings may have corrosion that causes the voltage to read low.

If the input voltage to TB1 is correct then replace the monitor.

**NOTE:** Do **NOT** use a battery charger to power the trailer. A battery charger does not output a pure DC voltage and will damage the onboard monitor.

### **System powers up and runs through power on test sequence OK, then flashes all sensor LEDs in an alternating pattern:**

This means that the monitor is not programmed.

1. Go to the PROGRAMMING section of this manual and program the monitor.
2. If the monitor fails to program, call FloTech for warranty status and an RGA number.

**System will not load and one or more RED sensor LEDs are lit in the inactive compartments:**

Follow these instructions for top or bottom sensors.

1. Remove onboard monitor cover.
2. Check the sensor inputs on TB3 and TB4 that are not being used (inactive sensor inputs). Make sure there are no wires connected.
3. Go to the PROGRAMMING section of this manual and repeat this procedure, making certain to accurately program the unit.
4. If the monitor still does not function properly, contact FloTech Technical Service for further instructions.

**System will not load and one or more RED sensor LEDs are lit in the active compartments:**

Follow these instructions for top or bottom sensors.

1. Remove onboard monitor cover.
2. Go to TB3. Remove sensor wire from the terminal block that corresponds with the lit LED. Example: If LED TOP #3 is lit, remove the sensor wire to terminal T3 (RED).
3. Select a compartment where the LED is NOT lit and exchange that wire with the suspect wire. Example: exchange failed sensor wire TOP #3 (RED) with the working TOP #2 wire (GRN).
4. If the lit sensor LED does not move to the new position, the monitor is defective. Example: LED TOP #3 top stays lit after the sensor wires are switched. Replace the onboard monitor chassis with a FloTech model FT207 replacement chassis.
5. If the lit sensor LED moves to the new switched compartment, the problem is with the sensor or wiring. Example LED TOP #3 go out and LED TOP #2 lights, return the wires to the original positions.

## FloTech Programmable CheckMate Retain / Overfill Monitor

6. Open all the sensor caps and check each wiring connection. Look for pinched wires that may short the sensor signal to ground. Also, look for defective crimp connections.
7. Measure voltage across the failed sensor wires (Black to Red). Voltage should measure 8-10 VDC.
8. If steps 6 and 7 check OK, replace the sensor with a FloTech FT150.

NOTE: A quick test of the sensor can be accomplished by connecting the sensor directly to the onboard monitor. Example: Remove sensors wires from monitor ground (WHT) and the TOP sensor 1 (BRN) and connect the sensor to be tested. If the sensor is good the RED TOP #1 LED will NOT light. If the sensor is defective the Diagnostic LED WILL light.

**System will not load, has no green AUX LED and no green PERMIT LED, power LED is lit and no red sensor LEDs are lit.**

1. Check the TB2 AUX input. This input must have a closed switch or jumper connected to allow the monitor to load. The AUX input has its own green LED. This LED must be lit to send a permissive signal to the load rack.
2. Check to see if a jumper is connected to TB2 AUX. If TB2 AUX has no connections, add a jumper.
3. If TB2 AUX has a wire connection, follow the cable to the switch. This switch is typically connected to a vapor recovery interlock or to a brake air lines interlock. Activate the switch and see if the AUX green LED is lit. If not repair the air switch. If the air switch appears OK, then check the monitor by installing a jumper wire to force the AUX LED on. If the Aux LED can't be forced on, then replace the monitor.

**Monitor's PERMIT and AUX LEDs are ON, all sensor LEDs are OFF, but the rack will not load.**

This condition usually indicates:

- The sensors and sensor wiring are functioning.
- The monitor has the proper power.
- The AUX connections are OK.
- Defective ground bolt or connections (if equipped).
- Socket output failed or socket wiring problem.

The problem usually lies in the monitor output, socket wiring or the socket itself. To troubleshoot this condition, use the FloTech FT520 Optic System Tester or a Scully Universal Tester

1. Check the system by connecting a FloTech FT520 Optic System Tester or a Scully Universal Tester to the Socket output. Check for a good light on all compartments.
2. If not permissive then check all wiring connections, poor crimp connections, or worn J slots on socket faceplate.  
NOTE: The ground hog bolt can fail or have a bad ground connection and not allow the tank to load. This is an independent system not part of the overfill system and is prone to problems.
3. If wiring connections check OK, test TB5 on the monitor using the FT520 Optic System Tester. The FT520 Optic System Tester is the only positive way to directly test Optic or Thermistor outputs. Follow the directions supplied with the FT520.

**System with Retain sensor will not reset when splash blending.**

1. Check continuity of reset switch with ohmmeter. When the switch is depressed the contacts are closed. If the switch is failed, then replace with a FloTech 10200A replacement switch.
2. If the switch tests OK, then replace the monitor.

## **Technical Support Hotline (877) 582-3569**

Contact the FloTech Technical Support Hotline for help:

- Troubleshooting overfill systems.
- Verifying defective components
- To request an RGA for defective FloTech products under warranty.